

Phy (103)

**COLLEGE OF ELECTRICAL & MECHANICAL  
ENGINEERING**

**FINAL REPORT**

**FABRICATION OF CADMIUM TELLURIDE SOLAR CELLS BY  
CLOSE-SPACED SUBLIMATION (CSS)**

**CONDUCTED UNDER PAKISTAN SCIENCE FOUNDATION  
GRANT NO. PSF/P-CEME/PHYS(103)**

**BY**

**COL DR NASIM A. KHAN PRINCIPAL INVESTIGATOR  
LT COL KHURRAM SAEED CO-PRINCIPAL INVESTIGATOR  
RESEARCH AND DEVELOPMENT CELL, COLLEGE OF EME  
RAWALPINDI**

PAKISTAN SCIENCE FOUNDATION  
FINAL RESEARCH REPORT  
From 15-6-1995 To 14-6-1997

1. Name and Address of Grantee **Col Dr Nasim A. Khan**
2. Project No: **PSF/P-CEME/PHYS(103)**
3. Title of Project : **FABRICATION OF CADMIUM  
TELLURIDE SOLAR CELLS BY CSS**
4. Amount of Grant: **5,09,682**

**SUMMARY STATUS OF FUNDS:**

- |  | <b><u>AMOUNT</u></b> |
|--|----------------------|
| 5. Total Grant Fund Received:  | <b>4,97,139.80</b>   |
| 6. Total Grant Funds Spent including this Report period:                               | <b>4,97,139.80</b>   |
| 7. Balance Grant Funds in hand on end of this report period:<br>(Item 6 from item 5):- | <b>NIL</b>           |

8. Estimated expenses for next period: **12,542.20 .**  
Signature of the Principal Investigator:- **Col Dr Nasim A. Khan**  
~~P. CEME/Phys(103)~~
10. Designation: **OIC College of E&ME  
Rawalpindi**
11. Date: **30 August 1997**
12. Signature of Official authorized  
to sign for grantee: **Brig Syed Shahid Mukhtar Shah**
3. Designation: **Commandant** *grewan*
14. Date: **30 August 1997** *Brig  
Comdt  
College of E&ME*

## FINAL RESEARCH REPORT 1995/1997

### Fabrication of Cadmium Telluride Solar Cells by Closed Spaced Sublimation

#### Summary

A decisive factor in large scale utilization of photovoltaic solar cells is its cost and all out efforts are being directed internationally to reduce the same at unprecedented rates. There are very few less developed countries which are able to join this race at the entry level. A break through in this direction was made during his PhD by the PI, based on which research efforts were initiated at the College of EME, Rawalpindi in 1993. These efforts were recognized by Pakistan Science Foundation in 1995 by providing a research grant of Rs 500,000.00. The research has been completed and all the objectives included in the original proposal have been achieved. During this period the research remained focussed on fabrication of thin films for low cost manufacture of solar cells by close-spaced sublimation.

This solar cell has three distinct layers of thin films; a tin oxide film under the glass acts as transparent top conducting layer, under it is deposited a layer of cadmium sulphide (CdS) which acts as n-type layer, and under this layer a p-type CdTe layer is deposited through close-spaced sublimation (CSS). The process of close-spaced sublimation is carried out in low grade vacuum created by mechanical pumps where the sublimation of material takes place in closed environments on to the glass super strate. This type of system was not available in Pakistan and the same has been designed and fabricated to fabricate solar cells based on this technology. In the proposed research four objectives were specified as shown below, and all of them have been achieved.

- OBJECTIVE-1.** Design and fabricate an experimental setup for deposition of CdTe solar cells by CSS.
- OBJECTIVE-2.** Deposit layer of CdS films by CSS.
- OBJECTIVE-3.** Deposit layers of CdTe films by CSS.
- OBJECTIVE-4.** Fabricate CdTe solar cells by CSS.

**Introduction** Wide spread deployment of PV cells for power generation, requires considerable progress in the manufacturing technology. High rate vapor deposition is presently used for large scale low cost deposition of thin films for packaging and other applications. The feasibility of using this technology for low cost deposition of solar cells is being explored. After an exhaustive literature survey cadmium telluride solar cell was found to be the most feasible candidate for high rate vapor deposition. Close-Spaced Sublimation (CSS), in which film deposition is carried out through sublimation by placing the substrate at a short distance from the source, provides an opportunity to fabricate CdTe photovoltaic (PV) solar cells at substantially higher rates than reported. It is considered as the most promising solar PV cells for low cost production [1,2]. CdTe solar cells with an efficiency around 15% have been reported else where

---

{<sup>3</sup>}. An effort was made to produce these solar cells at higher deposition rates to reduce the cost of manufacture of solar cells [<sup>4</sup>]. It was observed that the cells fabricated at higher deposition rates had similar open circuit voltages as those deposited at lower deposition rates.

2. The prerequisite for fabrication of low cost CdTe solar cell is environment having low vacuum with very precise temperature controls. The fabrication of a CdTe solar cell entails four distinct process steps. The first step after perfect cleaning of glass substrate is deposition of transparent and highly conductive tin oxide coating. In the second step 1 - 2 micrometer thick cadmium sulphide (CdS) layer is deposited on top of tin oxide coating. This is followed by the third step of depositing CdTe layer, 2 - 3 micrometer thick, on top of CdS while ensuring no direct contact between tin oxide and cadmium telluride layer. The last critical step is to make a back contact with CdTe and its heat treatment. The cell is now ready and if contact is made between tin oxide and back contact, designed voltage and current can be obtained under simulated sun or direct sunlight. The cell can then be encapsulated and arranged to meet the required voltage/current output.

### List of Scientists

3. Four MSc (Electronics) Engineering students were employed to work as graduate students on each layer of solar cell. It included Lt Col Javed Rushdi, who worked on spray deposition of Tin oxide films and developed a dedicated apparatus for these experiments. His paper "Transparent conducting oxide films by spray pyrolysis" was accepted and read in IEEE USA Multi Topic Conference held in Islamabad in 1995. He successfully defended his thesis and graduated in Mar 1996. Lt Col Khurram Saeed Sultan developed complete close-spaced sublimation experimental setup. He has enhanced its performance over a period of two years & graduated in 1996. Cadmium sulphide films were prepared by Lt Col Rizwan Hydri by CSS in the experimental setup developed by Lt Col Khurram Saeed. Lt Col Rizwan characterized his films by XRD and SEM and is compiling his thesis. The results of his research were presented in IEEEEP Multi Topic Conference held in Jan 1995 in Karachi. Lt Col Sikandar Qayyum conducted his research on CdTe films and successfully fabricated these films by CSS in the same experimental setup. He graduated in 1997 and the research results are included in his MSc Thesis "Thin Polycrystalline Cadmium Telluride Films by CSS", College of EME, 1997. Four final year engineering students were also employed on the project and have successfully fabricated these solar cells independently. The technology has also been made so simple that two diploma holders employed in this project attained proficiency in fabrication of solar cells in three months and are

- 
1. Brown J., Solar Cells, PHV Vol. 92, No. 2 p. 4
  2. Brown J., Final Technical Report, Phase I, Photovoltaic Manufacturing Technology, Final Subcontract Report, 1991, p.1
  3. Farakides C., PhD Thesis, University of Southern Florida, 1992.
  4. Khan Nasim A., PhD Thesis, Colorado State University, 1992.

currently working on next phase of the project. Another MSc engineering student has been employed for developing efficient back contact for enhancing efficiency of the solar cell.

### **Experimental Procedure**

4. The design of experimental set up was conceptualized based on the block diagram shown in Figure-1. The vacuum pumps having pumping capacity of 60 cubic meter per minute were provided by Dr A. Q. Khan. The design of the deposition chamber was based on the capacity of this pump and an arrangement to provide firm support to source and substrate heater. It has to house two such systems, provide adequate space for manipulation of source & substrate holders. Based on this conceptual framework the detailed design work was carried out on all the individual components i.e. various segments of the set up.

5. **Deposition Chamber.** The most important component was the deposition chamber as it involved careful tolerances for heater elements, thermocouple placement, expansion due to very high temperature, exact deposition of material etc. The chamber fabricated based on the above concept is shown in Figure-2. The placement of vacuum feed through/contacts for electrically operated heaters, thermocouple, source & substrate heaters and holders of heater in small place involved innovative designs due to local market support. In certain cases compromise had to be made to complete the experimental set up. An initial setup of mild steel which otherwise is an absolutely discarded material for vacuum was picked up for fabrication to reduce the initial cost.

Thin film depositing apparatus generally cost US\$ 17,000 (Rs 527,000) to US\$ 68,000 (Rs 2,108,000) in the international market and could have been made available in three months time. As opposed to this the cost incurred on set up that was designed, fabricated and developed in the College is approximately Rs 250,000.00.

6. **Electrical Feed Through.** To provide electrical connections inside the vacuum chamber was the next design problem, as the connections are made by utilizing vacuum feed-throughs. According to the design envisaged for the experimental set up, at least eight such electrical feed-throughs were required. The vacuum feed-throughs were not available in Pakistan and minimum cost of a feed-through was US\$ 200. The experimental set up required

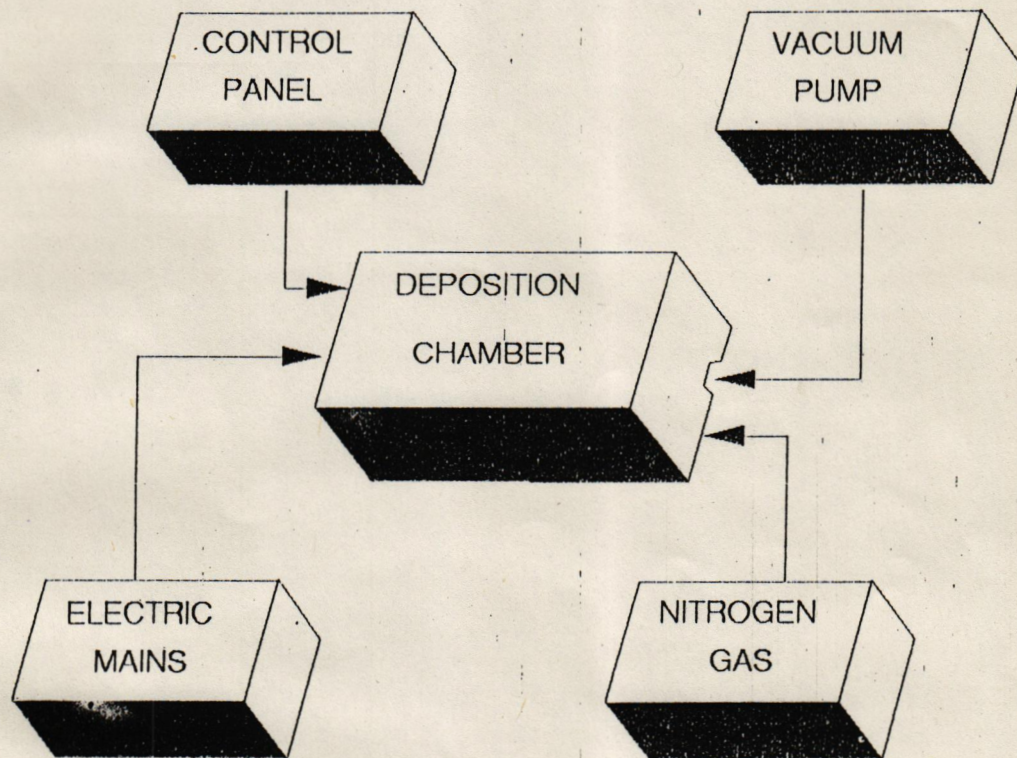
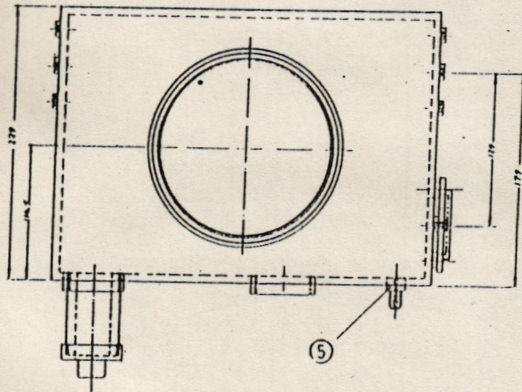
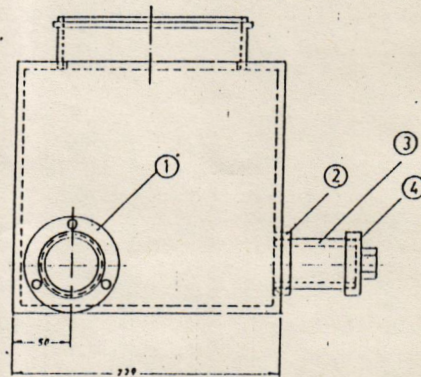
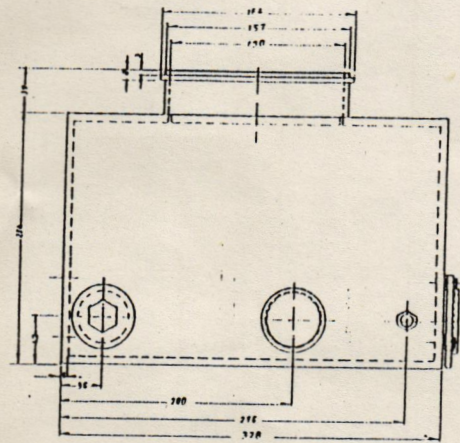

Figure:1 Block diagram of proposed experimental setup for deposition of solar cells



|                 |                          |                   |
|-----------------|--------------------------|-------------------|
| 5               | Gas inlet part.          |                   |
| 4               | Vacuum gauge adapter     |                   |
| 3               | Vacuum gauge part        |                   |
| 2               | Flange                   |                   |
| 1               | Vacuum feed through part |                   |
| S.No            | Name of part             |                   |
| Dated.. 07-6-96 | Assy Drawing             | Scale - 2mm = 1cm |
| Drawn by B & S  | SOLAR CELL               |                   |
| Checked By      | APPARATUS DEPOSITION     |                   |

FIG-2 SOLAR CELL DEPOSITION CHAMBER



minimum of eight feed-throughs costing US\$ 1600. To reduce this prohibitive cost, the vacuum feed through were therefore again designed, developed and fabricated at the College from Teflon rod.

7. **Temperature Control.** For CSS technology extensively high temperatures in the range of 1000 degrees Celsius are to be maintained in a small enclosed space of vacuum. The close maintenance and monitoring of such temperature requires an extremely sensitive pyrotechnics and an equally responsive control system. This was very carefully designed and the components procured from market after a very extensive and painstaking effort.

8. **Humidity Control.** The humidity in the chamber is very critical. The system has to be purged a number of times to ensure that traces of any moisture are removed from the chamber. This was overcome by incorporating nitrogen gas purging facility in the chamber with adequate controls.

9. **Solar Cell Deposition System.** The film deposition chamber is made of steel having three sets of vacuum feed-throughs, one port for vacuum pump and another port for vacuum gage. A special viewing glass is placed on top to monitor the substrate during deposition, it also gives access inside the deposition chamber for installation and removal of heaters, thermocouple, and substrate etc. The chamber houses heaters for substrate & source, thermocouple and their holders. To ensure accurate & uniform temperature, graphite was utilized for source and substrate heating. The closeup of this setup is shown in Figure-3, where glass substrate is sandwiched between source & substrate. The deposition chamber (Photograph-1) shows one vacuum feed through, vacuum gage, vacuum pump inlet pipe, and top cover. Photograph-2 shows the internal configuration of deposition chamber. This view shows the substrate heater, heater holder, thermocouple, sources shield and thermocouple holder.

10. **Complete Experimental Setup.** Complete experimental setup consist of vacuum pump, deposition chamber, temperature controller, vacuum gauge & gas cylinder as shown in Photograph-3.

11. **Results & Discussion.** Based on the experimental set up, depositions have been successfully made. It is seen that CdS and CdTe films formed at the requisite temperature are of good quality and stick well with the glass. A series of tests were carried out and individual results and associated discussion are given in subsequent paragraphs.

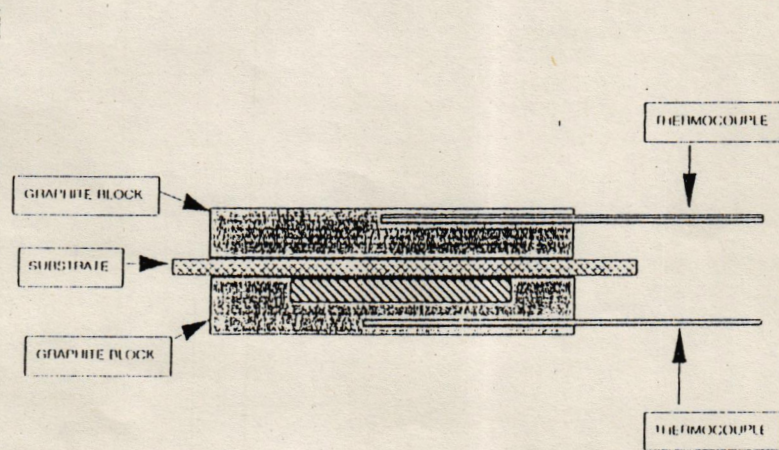
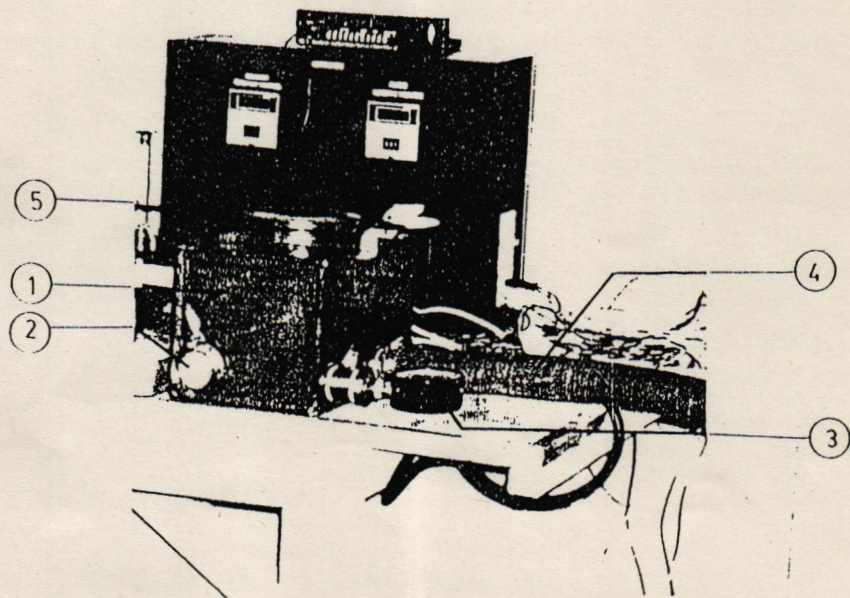
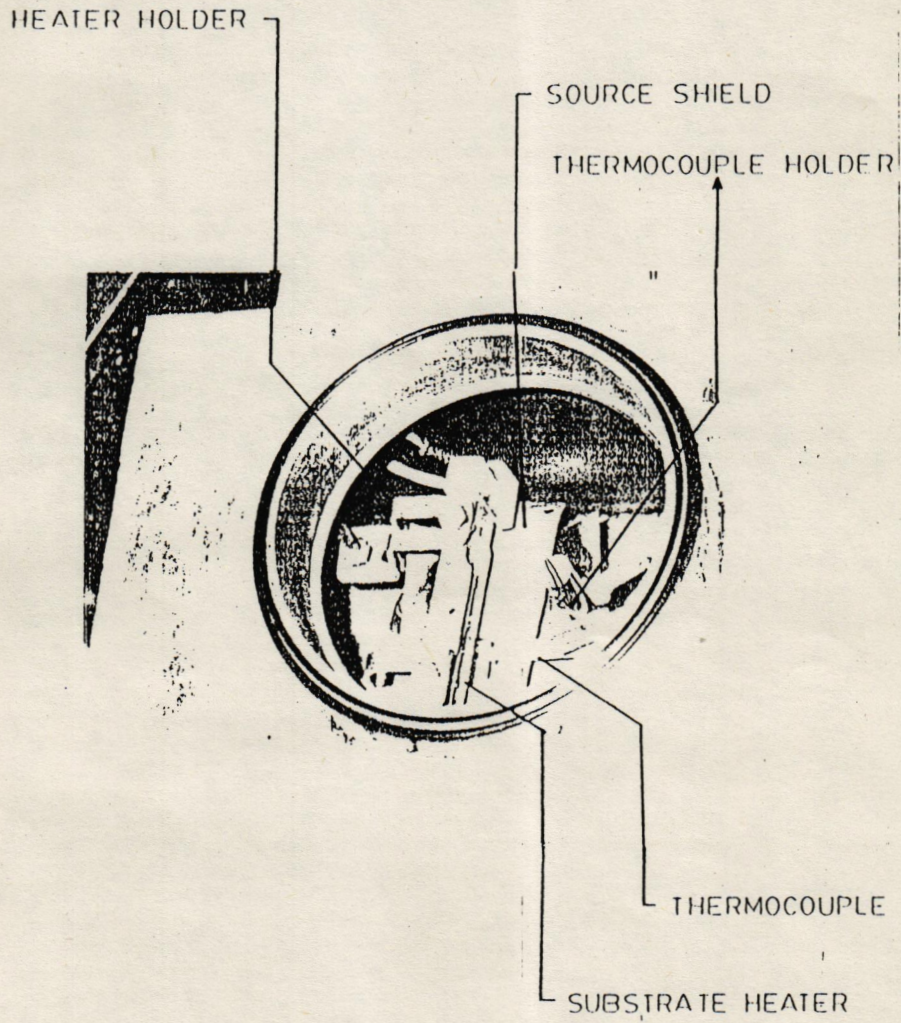

Fig. 3 Substrate sandwiched between graphite blocks for source and substrate



1. DEPOSITION CHAMBER
2. VACUUM FEED THROUGH
3. VACUUM GAGE
4. VACUUM INLET PIPE
5. TOP COVER

PHOTOGRAPH - 1 VACUUM DEPOSITION CHAMBER



PHOTOGRAPH-2 INTERNAL CONFIGURATION OF DEPOSITION  
CHAMBER

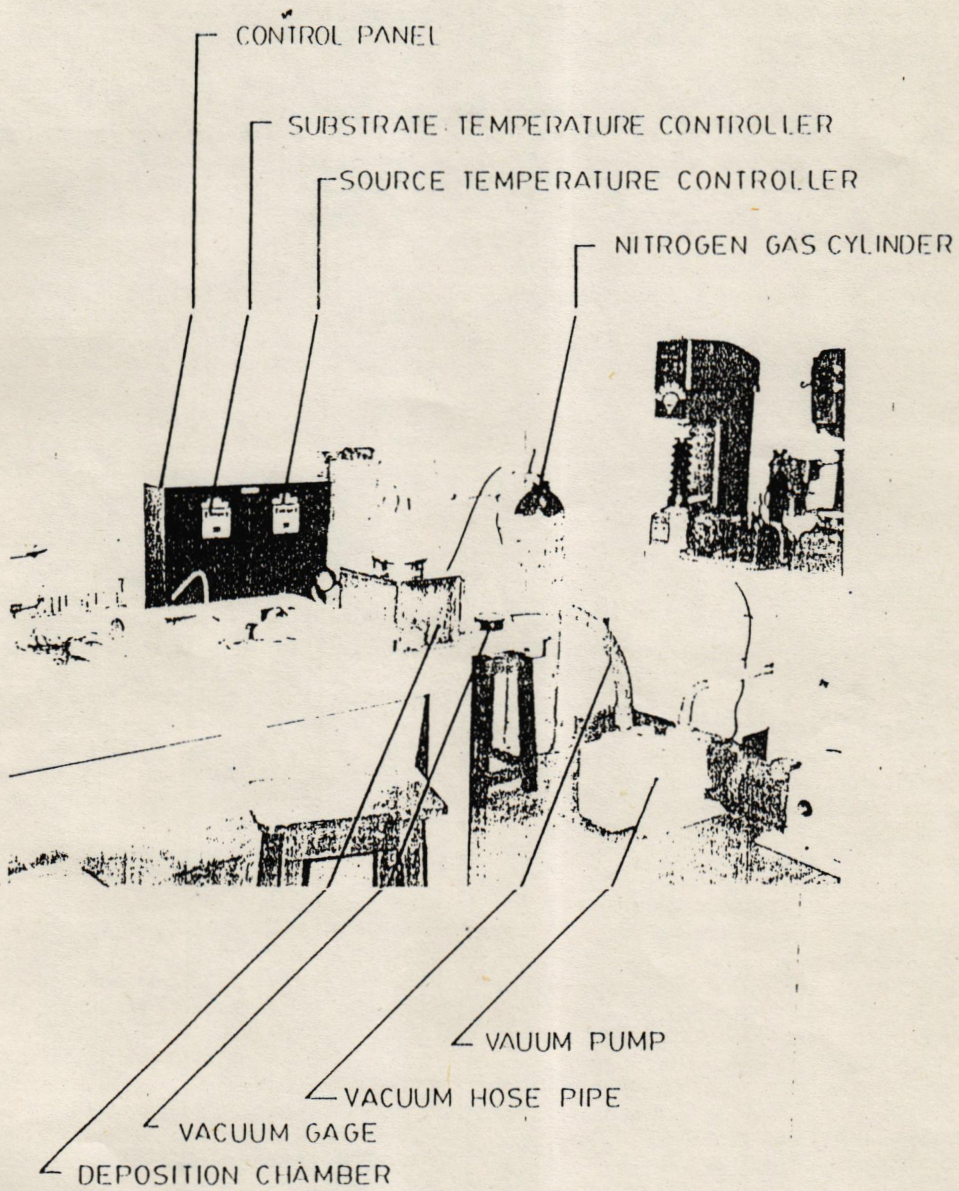

PHOTOGRAPH-3, COMPLETE EXPERIMENTAL SET UP

12. **Thin CdS Film Growth.** Based on the experimental set up, depositions have been successfully made. It is seen that CdS films formed at the requisite temperature are of good quality and stick well with the glass.

13. **Discussion.** The CdS films are quite thick and in some cases very small CdS crystal have flown directly to the substrate and got embedded in the film. To ensure better quality films and consistency, it requires repeated experimentation & improvement of the source crucible. The thickness uniformity has also to be improved by adequate controls like thickness detectors.

14. **Optical Transmission Spectra.** Optical transmission of the films were recorded on a Jerrell-Ash Monochromator. Transmission spectra of one of the samples is shown in Figure-4. The sample was deposited at a source temperature of 720 C with deposition time of 1 minute and 30 seconds.

15. **Discussion** From transmission spectra, film thickness and refractive index of the film have been calculated using the method of Manificier et. al [7]. The thickness of the film is 1.7  $\mu$ m which gives a growth rate of approximately 1  $\mu$ m per minute. Refractive index (n) of the film has been calculated to be 2.11 which compares well with the standard value of 2.4 for CdS[8].

16. **Scanning Electron Microscopy** Scanning Electron Microscope (SEM) micrographs have been obtained using AMRAY 1830 I SEM. The sample used for SEM had also been deposited at same temperatures as in the case of sample used for optical spectroscopy, however, deposition was allowed for a period of 1 minute and 15 seconds. Micrographs obtained are shown in Figure-5. In case of Figure 5b the sample was tilted at an angle of 16 degrees, which resulted in better focussing even at higher magnification.

17. **Discussion.** The results show a continuous but porous and coarse film having a similar pattern. The average grain size is approximately 4  $\mu$ m. The exact evaluation of grain size has to be improved to ascertain the uniformity of films.

18. **Energy Dispersive X-Ray Spectrography.** This has been done using EDAX PV9700 system installed in the same SEM mentioned above. The energy dispersion plot shown in Figure-6 was obtained using the same sample whose SEM micrograms are shown in Figure-5. In order to cover relatively large area of the film, magnification factor was limited to 47 times.

19. **Discussion.** The plot in Figure-6 shows sulphur peaks at energy value of 2.307 eV. Cd peaks are at 3.132, 3.314, 3.527, 3.716, and 2.764 eV. The peak at 0.145 is considered to be because of the barium window used in the EDAX sensor. The results show a good stoichiometric ratio for the film. The following discussion of XRD results, for another sample deposited under similar conditions supports these results.

## VISIBLE LIGHT TRANSMISSION

CADMIUM SULPHIDE FILMS DEPOSITED BY CSS  
FILM THICKNESS APPROX 1.7 MICROMETER

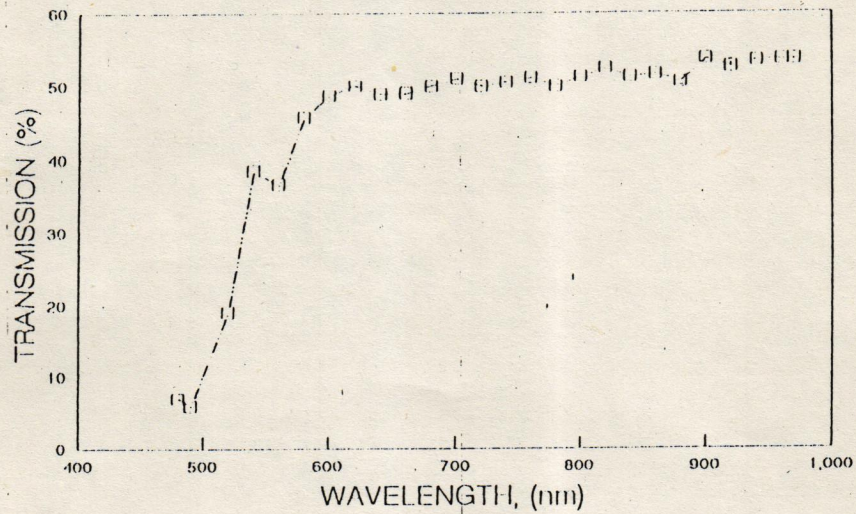
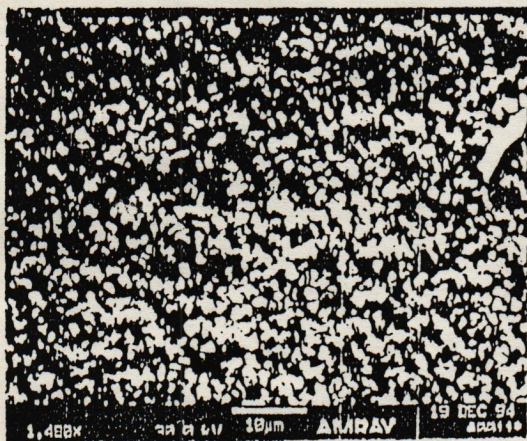
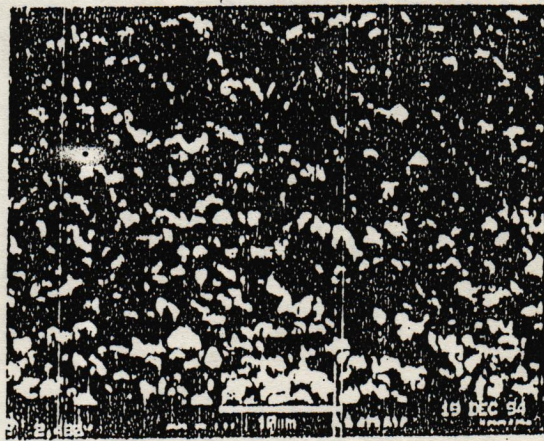

Fig-4



a.



b.

Fig - 5. SEM micrograms of CdS thin film deposited by CSS on glass substrate: (a) Film plane a right angle to the electron beam; (b) Film plane at 16° to the electron beam.

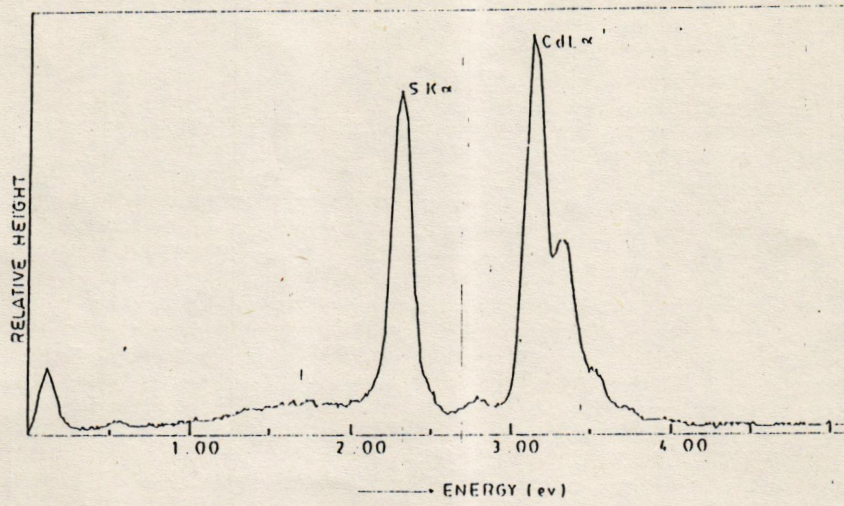

FIG. 6:- ENERGY DISPERSIVE X-RAY MICRO ANALYSIS OF THIN SEMICONDUCTOR CdS FILM

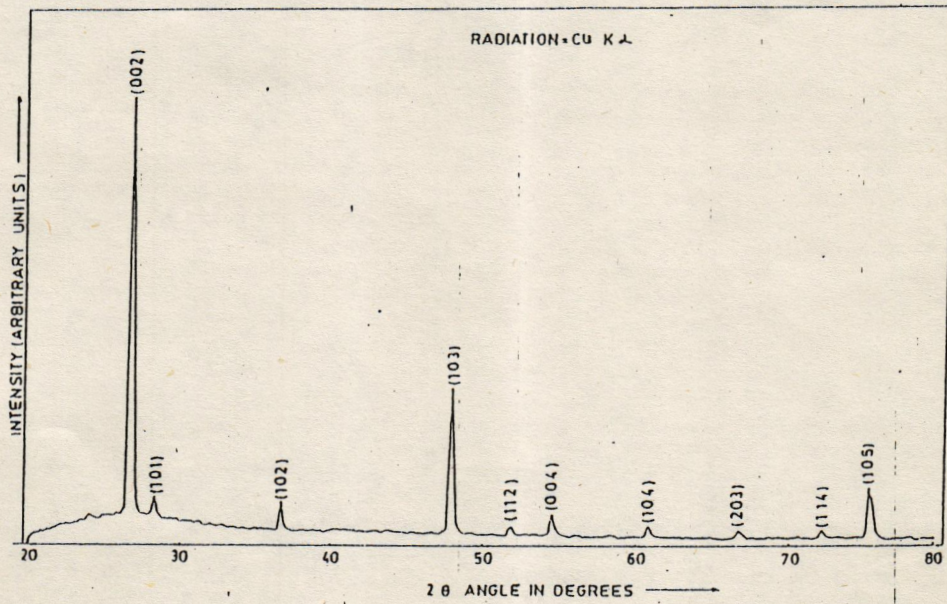

FIG 7:- X-RAY DIFFRACTOGRAM OF CdS. THIN FILM THICKNESS  $\sim 1.7 \mu\text{m}$



20 **X-Ray Diffraction (XRD).** XRD measurement was carried out on a JEOL powered diffractometer with Ni-filtered CuK radiation working at 40 Kv 30 mA in reflection geometry for 20-80 2 $\theta$ -scan range. Sample mentioned at para 6 has been used for XRD. The x-ray diffraction pattern of the film is shown in Figure-7. The respective inter planer spacing 'd' values along with relative intensities and miller indices are given in Table-1. For comparison, standard data for CdS from JCPDS No 6-0314 has also been tabulated along with side.

**Table 1: Comparison between Inter planer spacing and relative intensities of a sample of CdS thin film with standard values.**

| d(A0) | Sample of CdS |            | Standard Data for CdS JCPDS Card No 6-0314 |            | Miller |
|-------|---------------|------------|--|------------|--------|
|       | Intensity     | (relative) | d(A0)                                      | Intensity  |        |
|       |               |            |  | (relative) | Index  |
|       |               | 3.58       |  | 75         | 100    |
| 3.151 | 100           | 3.36       |  | 60         | 002    |
| 3.161 | 06            | 3.16       |  | 100        | 101    |
| 2.155 | 07            | 2.45       |  | 25         | 102    |
|       |               | 2.068      |  | 58         | 110    |
|       | 11            | 1.898      |  | 40         | 103    |
|       |               | 1.791      |  | 18         | 200    |
| 1.765 | 02            | 1.761      |  | 45         | 112    |
|       |               | 1.737      |  | 18         | 201    |
| 1.681 | 06            | 1.679      |  | 04         | 004    |
|       |               | 1.581      |  | 08         | 202    |
| 1.571 | 04            | 1.52       |  | 02         | 104    |
| 1.46  | 02            | 1.398      |  | 16         | 203    |
| 1.308 | 02            | 1.303      |  | 08         | 114    |
| 1.261 | 11            | 1.257      |  | 12         | 105    |

21 **Discussion.** The result illustrates that the film is polycrystalline. The variation from the standard values (Table-1) is because of preferred orientation along 002 crystallographic plane. The good match of results with the standard CdS X-ray data indicates a good stoichiometric ratio and non-detectable presence of impurities.

22 **CdTe Film Growth.** The CdTe film grown by CSS very quickly various CdTe films grown are shown in Photograph-4 are metallic grey black in colour.

23 **Discussion.** The film thickness control was very challenging as rate of deposition is very high and strongly depends on temperature gradient between source & substrate.

24 **X-Ray Diffraction.** CdTe films were characterized with the help of Siemens X-Ray Diffraction system. The X-Ray pattern of two different films shown in Figures 8 & 9 show identical peak at  $2\theta = 27.5$  degree. The location of minor peaks is same however the intensity varies considerably. The dispersion of the contour pattern of two different sample in 111 pole Figure 10 & 11 are quite similar however magnitude varies significantly. The dispersion of contour pattern of same two samples in 220 pole Figure 12 & 13 are also quite close and magnitude is also quite close. Overall XRD indicates quite uniform films of CdTe as grown in this setup by CSS.

25 **Solar Cell Characterization.** The solar cells fabricated above were tested on a temporary set up and were exposed to 100 W incandescent light to simulate the energy of sun i.e. 1000 Watt per square meter of solar radiation falling on earth, and solar cells were seen to

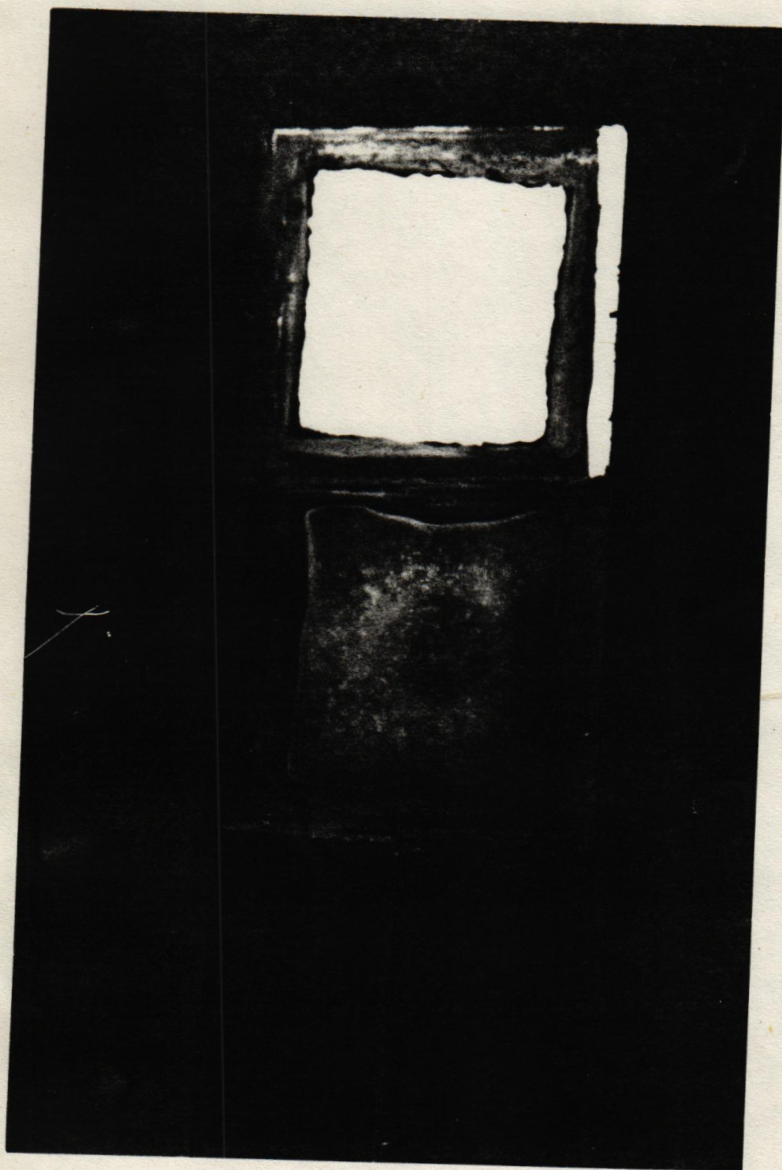

Complete CdTe Solar Cell  
with Silver Back Contact

CdTe Layer

CdS layer

Photograph - 4 Development of CdS/ CdTe Layer by CSS in to a complete Solar Cell

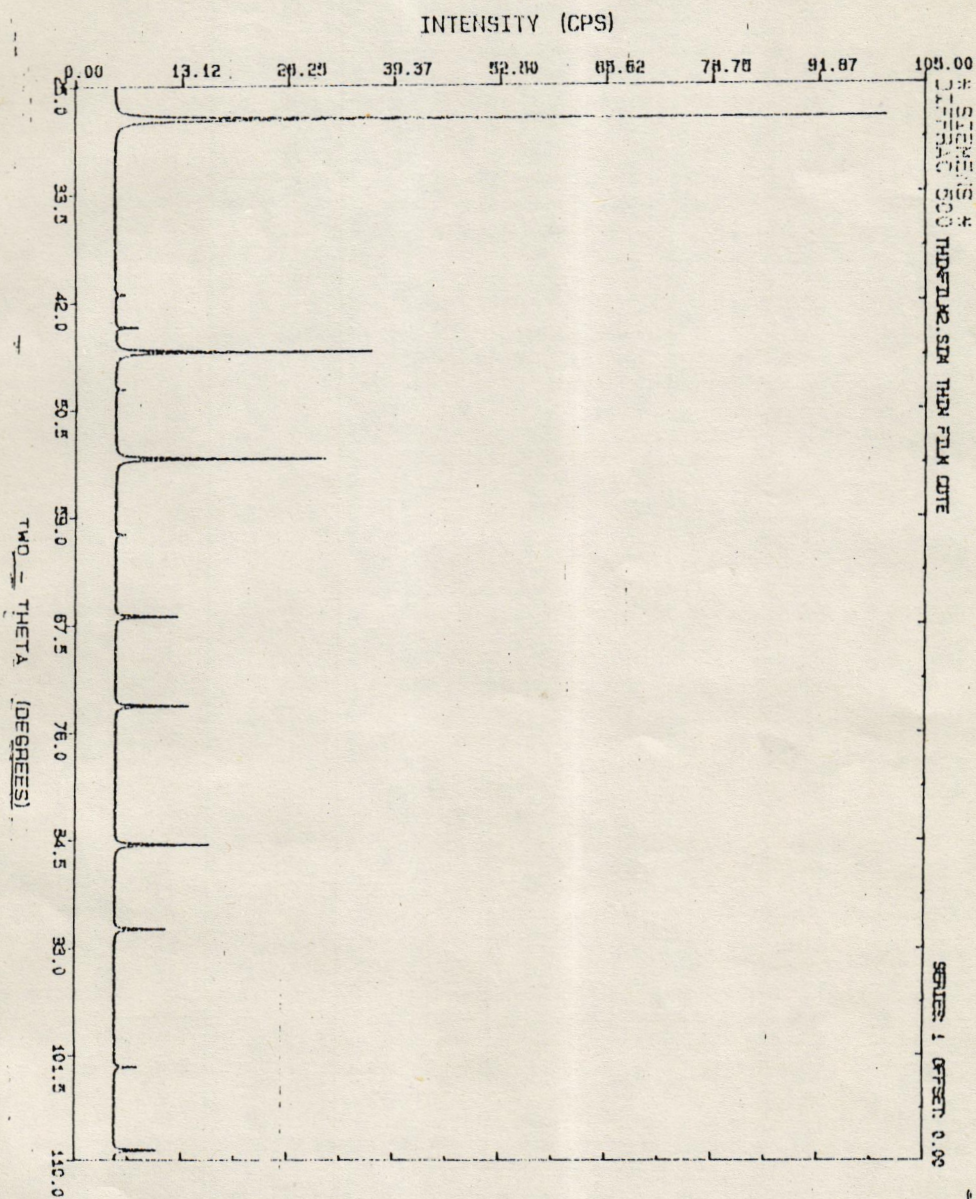

Figure 8 x RD of CdTe Film Sample thin film 2 grown by CSS

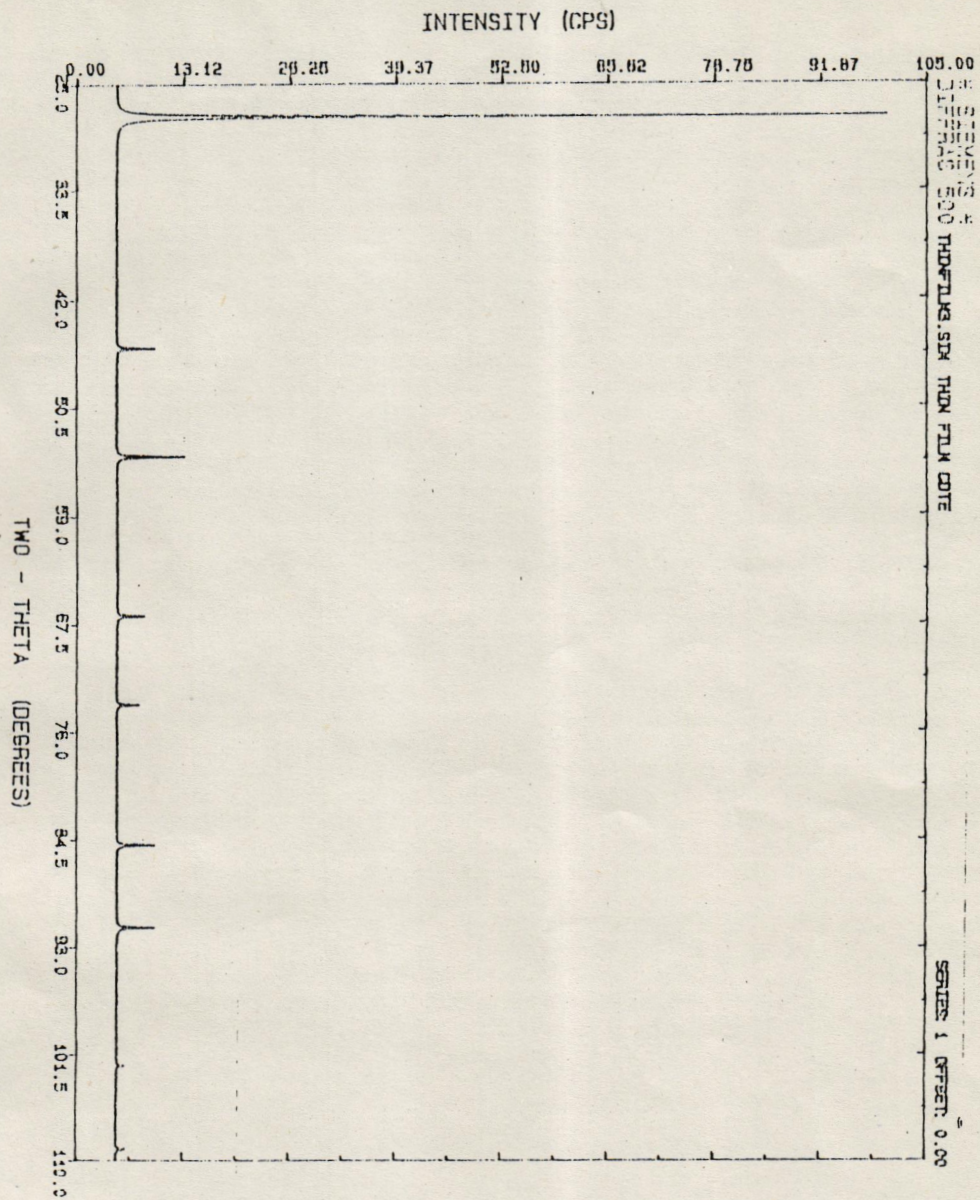
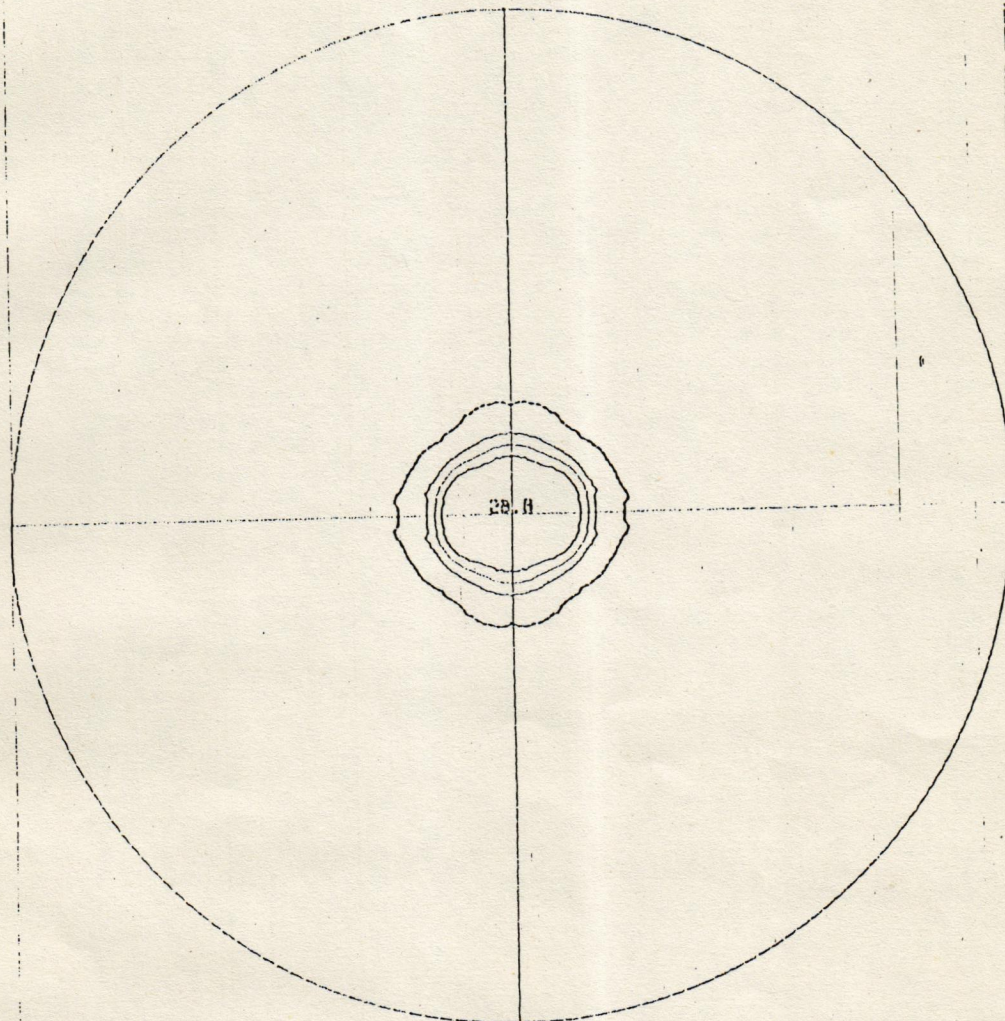

Figure 9 x RD pattern of CdTe Film sample thin film 3 grown by CSS

SIEMENS \*TEX11\*

Longitudinal Direction



111 Pole figure (Symmetrised x 4)

SAMPLE: CDTE2  
IDENT.: THINFILM

DATE: 23-OCT-96 08: 41

Figure 10 - 111 pole Figure of CdTe thin film sample CdTe 2 grown by CSS

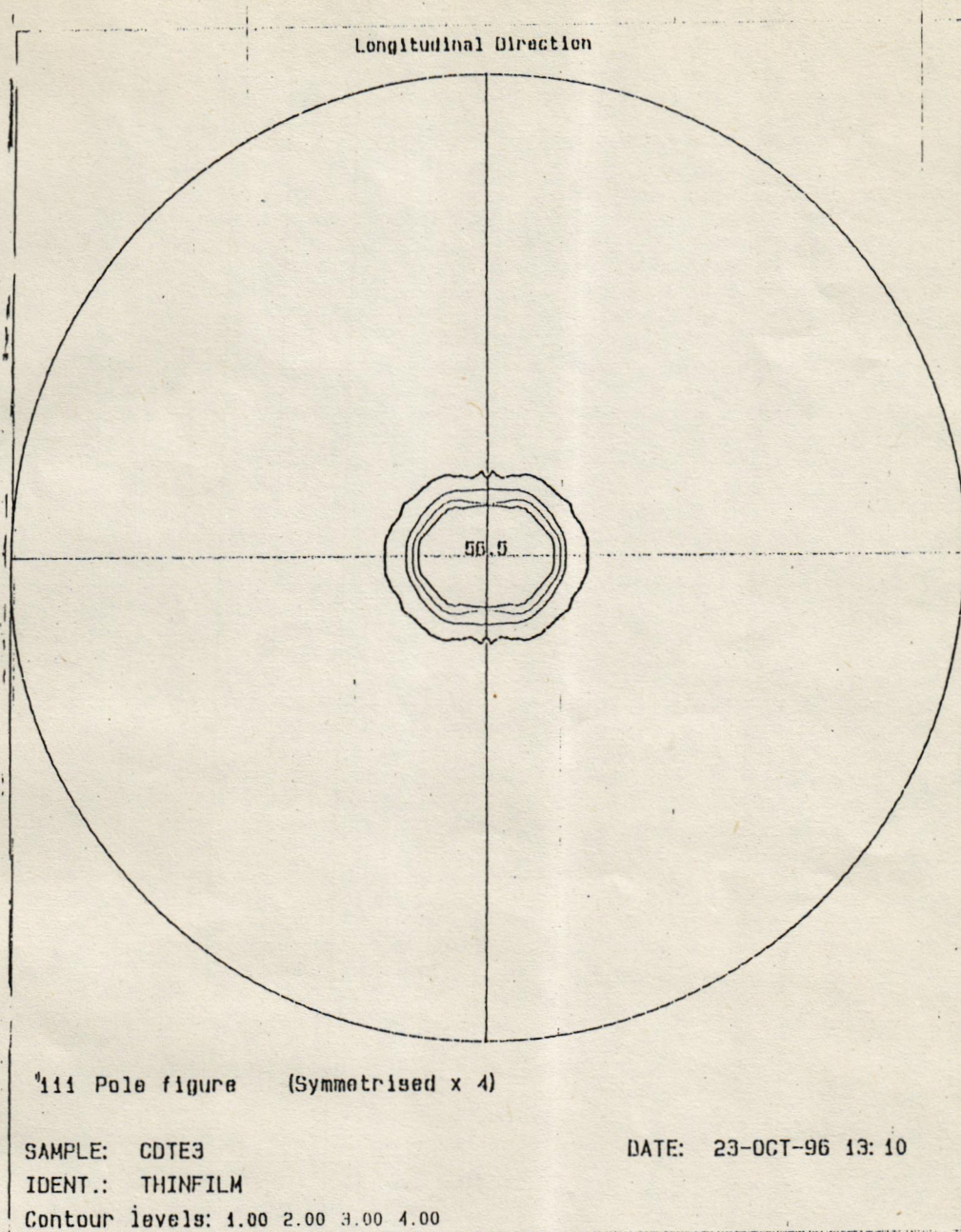
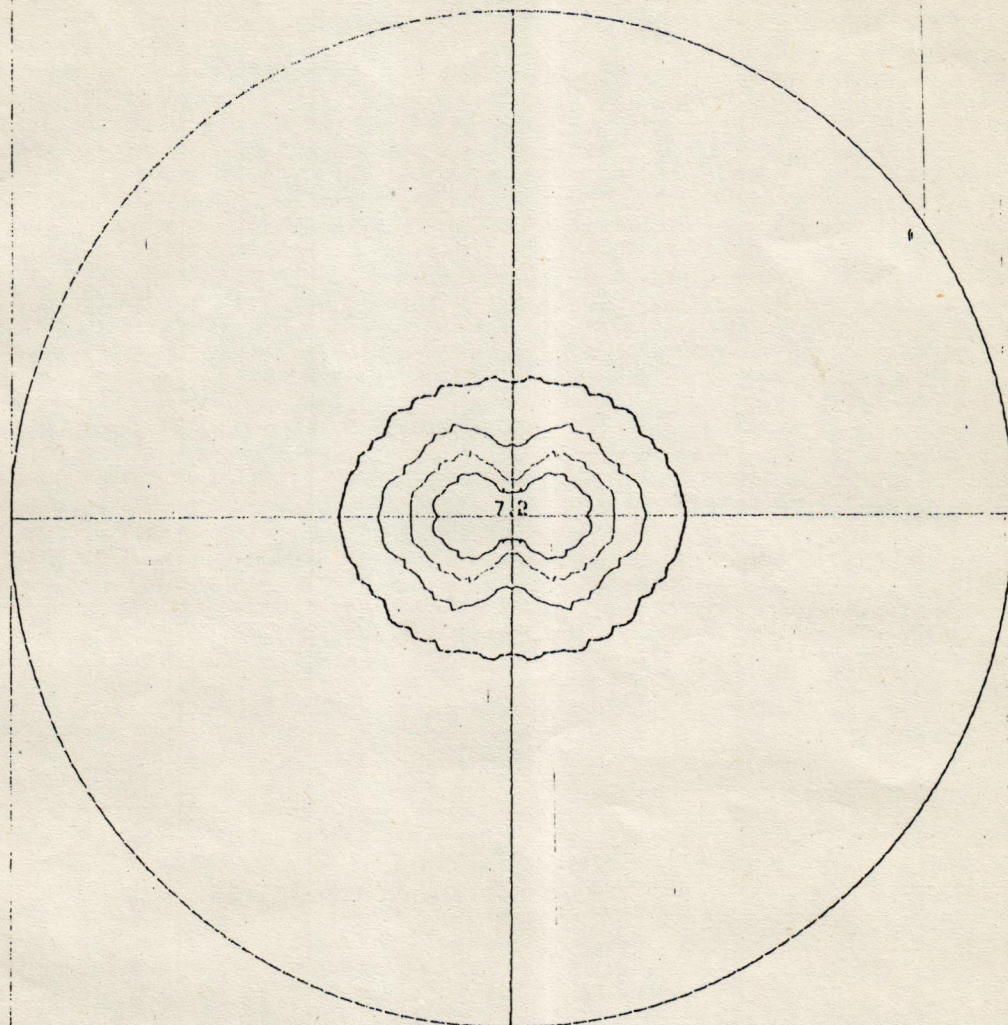

Figure 11. 111 pole Figure of CdTe thin film sample CdTe 3 grown by CSS

SIEMENS \*TEX11\*

Longitudinal Direction



220 Pole figure (Symmetrised x 4)

SAMPLE: CDTE3  
IDENT.: THINFILM

DATE: 23-OCT-96 13:15

Figure 12 22 pole Figure of CdTe thin film sample CdTe3 grown by CSS

SIEMENS \*TEX11\*

Longitudinal Direction

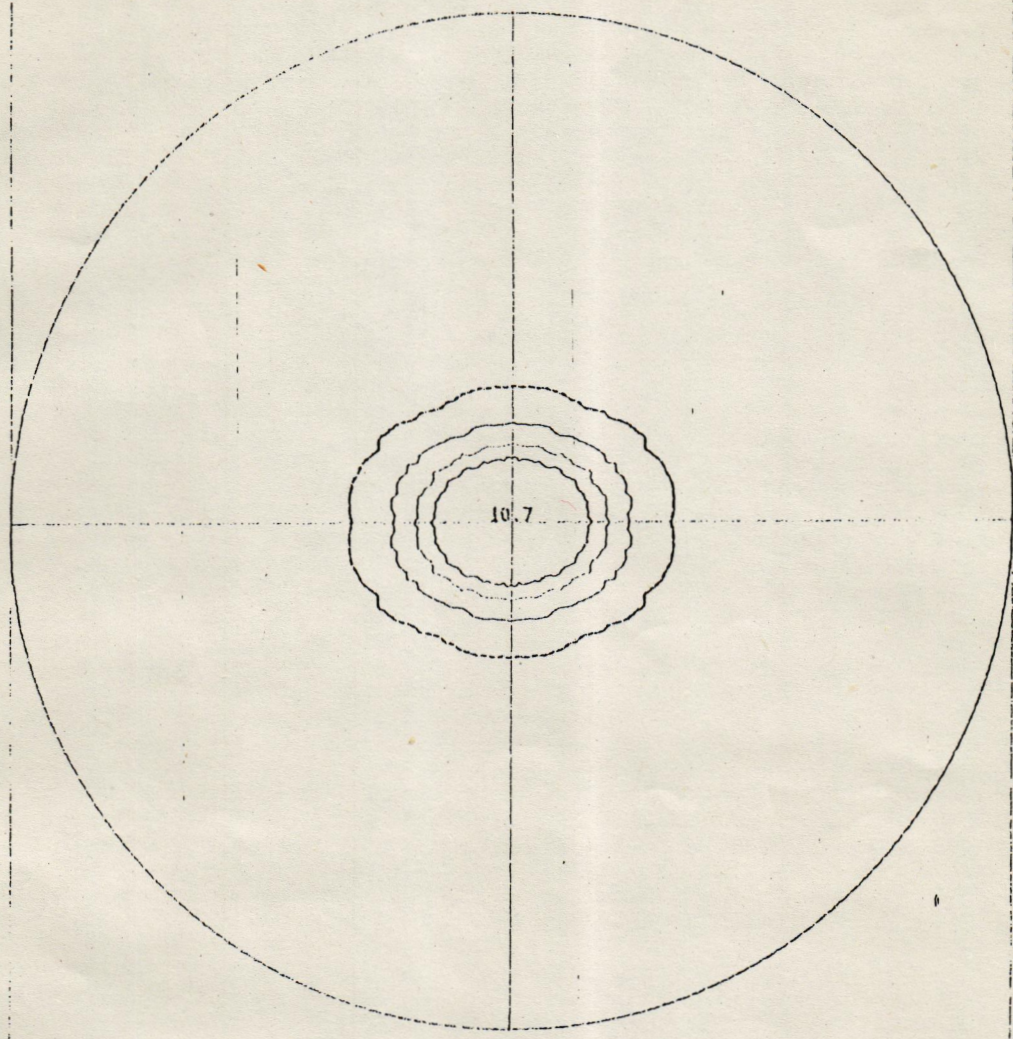

220 Pole figure (Symmetrized x 4)

SAMPLE: CDTE2  
IDENT.: THINFILM

DATE: 23-OCT-96 08:50

Figure 13 220 pole Figure of CdTe thin film sample CdTe 3 grown by CSS



produce voltage between 0.45 to 0.6 V. A series of  $1 \text{ cm}^2$  CdTe solar cells have been prepared by CSS technology and they have been connected to develop a module producing  $V_{oc}$  of 6 Volts and  $I_{sc}$  of 1.5 milliamperes. Individual cells producing 0.5 Volts and 7 milliamperes have also been produced.

26. **Discussiona.** The CdS films are quite thick and in some cases very small CdS crystallites had flown directly to the substrate and got embedded in the film. To ensure better quality films and consistency, it requires repeated experimentation & improvement of the source crucible. The thickness uniformity has also to be improved by adequate controls like thickness detectors. b. CdTe film is of 10 - 12 micrometer thick and some of granules of cadmium telluride have flown and got deposited on the glass. This can be over come by utilizing multi compartment source crucible. The uniform thickness can also be obtained by uniform heating of the source and substrate.

27. **CdTe Solar cell Modules.** The solar cell fabricated in this system have been connected in series & parallel to produce modules of 3V, 6V and are connected to operate calculator and watch as shown in Photograph-6.

28.  **$16 \text{ cm}^2$  CdTe Solar Cell.** The size of CdTe solar cells has been enhanced from  $1 \text{ cm}^2$  to  $4 \text{ cm}^2$  (Photograph-7) to  $16 \text{ cm}^2$  and all are producing similar open circuit voltages. The same are shown in photograph-8.

### Conclusions

29. **This is the first time films for CdTe solar cells have been fabricated and reported in Pakistan using CSS technology.**

The solar cell manufacturing setup using CSS technology has been completed with a very limited budget. The demonstration of fabrication of solar cells with such a limited budget leads to a firm conclusion that this technology must be adopted rigorously in Pakistan. The total time involved in the design, development and making the setup completely functional was so short that it further supports the argument of pursuing this technology.

30. Pakistan is SOLAR RICH and all efforts in the direction of utilization of this potential will bring ENERGY SECURITY to the country. The potential of this technology can bring energy at the door steps of all Pakistanis and uplift the living standard of the country. The utilization of solar energy will also reduce the pollution and result in cleaner environments. It is also expected that due to less dependance on import of oil a great potential of foreign exchange savings exists. The human resources component of this research is extremely valuable for our country. There is an acute shortage of technologist in the area of rapidly growing field of photovoltaic, and effort in developing such technologist must begin. If expeditiously exploited the results of this research can it self be a good source of earning to Pakistan.

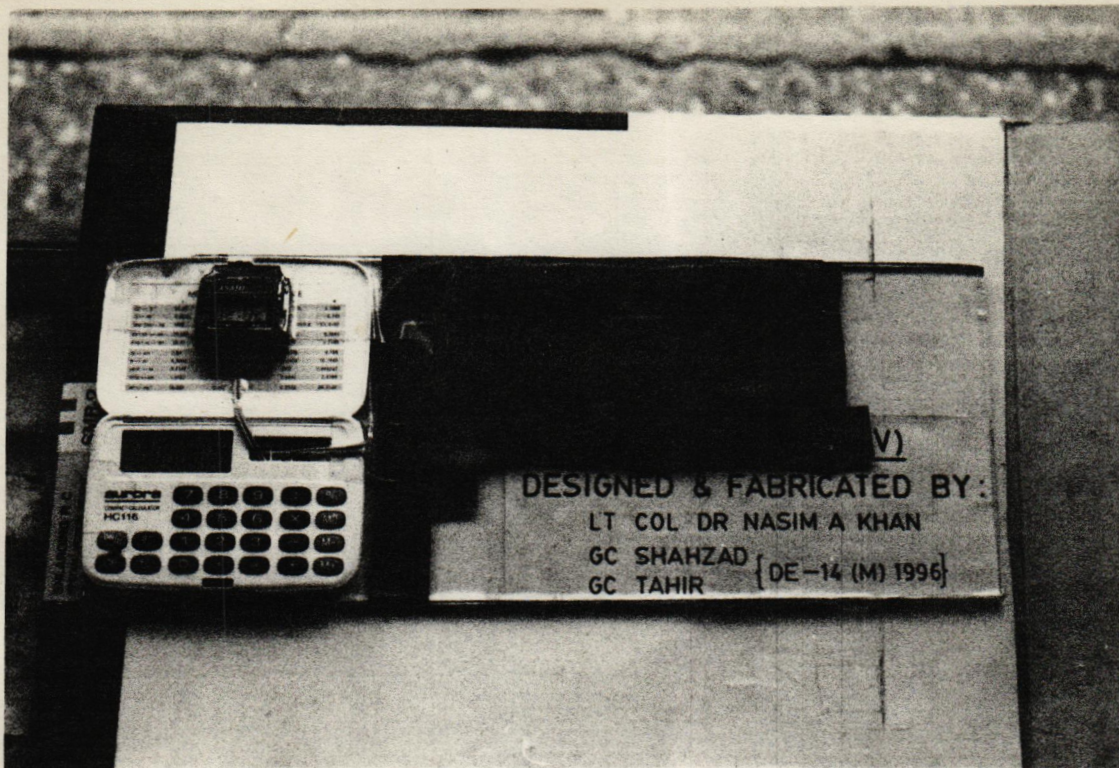

Photograph 5

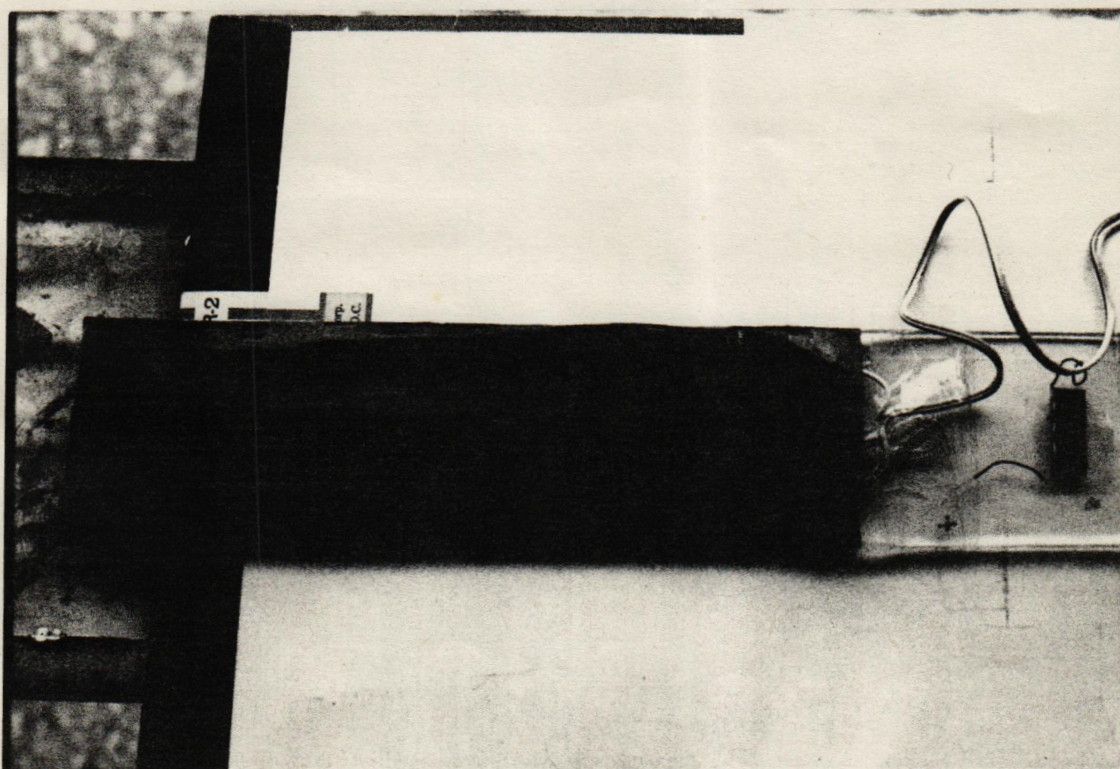

Photograph 5b

Photograph 5 Cadmium Tellurite Solar Cells connects in series and Parallel to operate calculator and watch photograph 5 (a) and produce 6v photograph 5b.

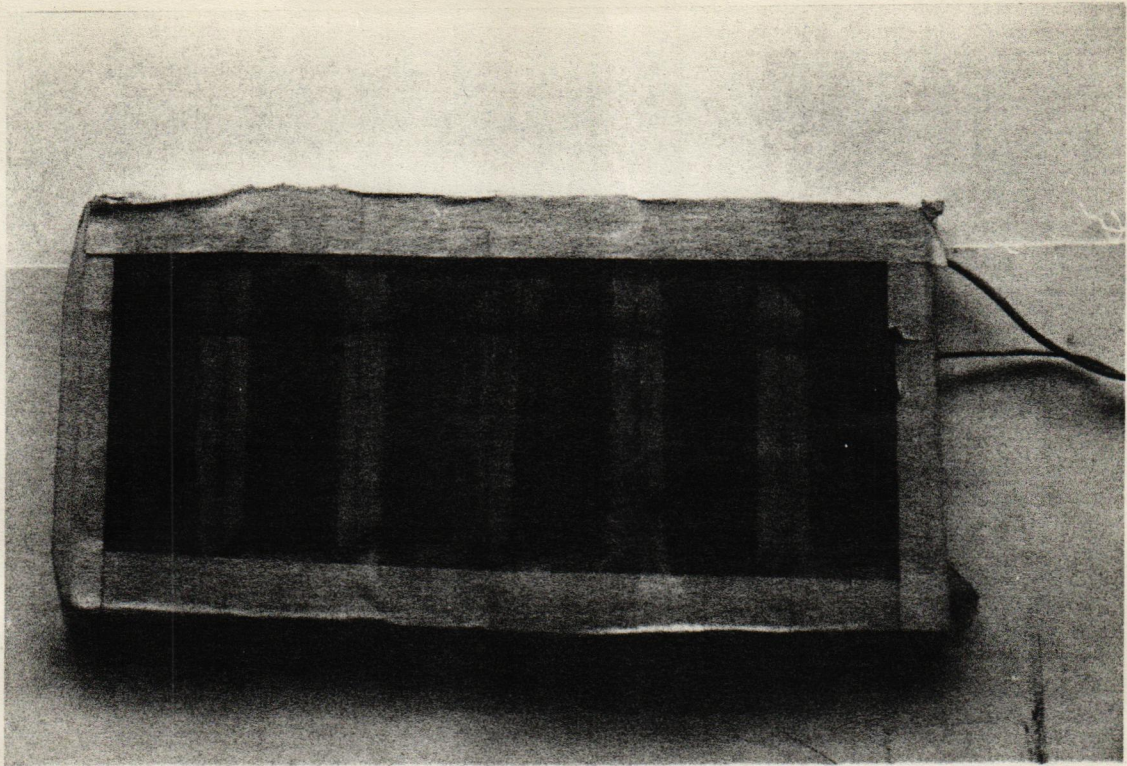

Photograph

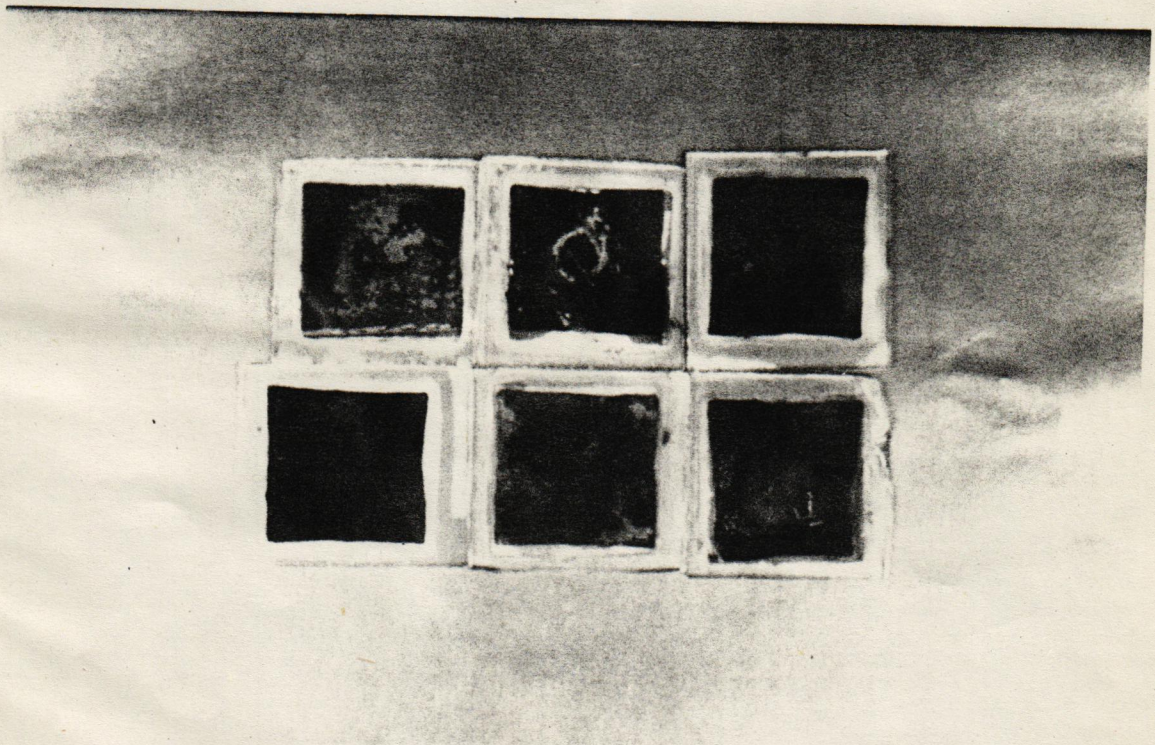

Photograph 6b

Photograph 6 Cadmium Tellurite Solar Cells  $4 \text{ cm}^2$  3v module (6a) and  $16 \text{ cm}^2$  3v module (6b).

## Recommendations

31. The research needs to be simultaneously carried out in following areas:
- a. Deposition of highly conductive ultra thin tin oxide coatings. The sheet resistance recommended is of the order of 9-15 ohms per square.
  - b. Production of less than a micron thick, pore free, n-type CdS layers at high deposition rates.
  - c. Fabrication of 2 micron thick uniform thickness CdTe, at very high deposition rates.
  - d. Completion of solar cell by providing adequate back contact to CdTe layer. This is critical because of the nature of CdTe material which does not lend itself to easy method of back contact.
  - e. Evaluating the impact of deposition rates on the quality of solar cells.
32. **Plan for Future Work.** The project was phased in Two years, and the actions were closely adhered. It is now proposed to develop a continuous lab scale solar cell fabrication system for which proposal has been deposited with PSF and Min of S&T.
33. **Publications**
- \* Sikandar Qayyum, Thin Film Polycrystalline Cadmium Telluride films by CSS, MSc Thesis, College of EME, 1997.
  - \* Khurram S. Sultan, Thin film fabrication by CSS, MSc Thesis, College of EME, 1996.
  - \* Javed Rushdi & Nasim A. Khan, Transparent conducting oxides by spray deposition, IEEE Multi Topic International Conference, NUST, Rawalpindi, Nov 27-28 1995.
  - \* Khan Nasim A., CdTe solar cells in Pakistan, Proceeding of Nathiagalli International Summer College, Jul 25-Aug 4, 1995.
  - \* Nasim A. Khan and Rizwan A. Hydri, Thin semiconductor CdS films by close-spaced sublimation, IEEEEP International Symposium 1995, Karachi, The Engineer, Jan 95 p20
  - \* Nasim A. Khan and Khurram S. Sultan, CdTe thin films by close-spaced sublimation, IEEEEP International Symposium 1995, Karachi, Jan 28-29, 1995.
  - \* Nasim A. Khan, Manufacturing of low cost solar cells in Pakistan, Seminar SDPI, The News, 10 April, 1995
  - \* Nasim A. Khan, Low cost manufacture of cadmium telluride solar cells in Pakistan, COMSTECH, NIST, Inter Islamic Network on Science and Technology Conference, Islamabad, Aug- Sept, 1994.

AUDIT REPORT

1. The account of Pakistan Science Foundation project P-CEME/Phys(103) entitled "Fabrication of CdTe Photovoltaic Cells by Close-Spaced Sublimation (CSS)" has been audited for the duration between June 1995 to June 1997. The comments are given below:-

- a. The first instalment of the account of Pakistan Science Foundation (PSF) project CEME/Phys(103) entitled "Fabrication of CdTe Photovoltaic Cells by Close-Spaced Sublimation (CSS)" funds released by Pakistan Science Foundation (PSF) for a sum of Rs 3,94,564.00 (Rupees three lac ninety four thousand five hundred sixty four only) received vide Pakistan Science Foundation letter no PSF/Res/P-CEME/Phys (103) dated 19 June 1995. Subsequently a sum of Rs 47,435.30 (Rupees forty seven thousand four hundred thirty five and paisa thirty only) was released vide Pakistan Science Foundation letter no PSF/Res/P-CEME/Phys (103) dated 14 December 1996 as 2nd & 3rd instalment and finally a sum of Rs 29,873.00 (Rupees twenty nine thousand eight hundred seventy three only) was released by Pakistan Science Foundation vide their letter no PSF/Res/P-CEME/Phys (103) dated 25 March 1997.
- b. The total grant approved for the project was Rs 5,09,682.00 (Rupees five lac nine thousand six hundred eighty two only) as per agreement but only a sum of Rs 4,71,872.30 (Rupees four lac seventy one thousand eight hundred seventy two and paisa thirty only) has been released and net interest received from bank is Rs 25,267.50 (Rupees twenty five thousand two hundred sixty seven and paisa fifty only) [i.e. interest earned Rs 28,075.00 (Rupees twenty eight thousand seventy five only) {-} W.H. Tax deducted Rs.2,807.50 (Rupees two thousand eight hundred seven and paisa fifty only)]. The total amount received including interest thereon amounting to Rs 4,97,139.80 (Rupees four lac ninety seven thousand one hundred thirty nine and paisa eighty only) has been expended. The balance amount of Rs 12,542.20 (Rupees twelve thousand five hundred forty two and paisa twenty only) may please be released to fulfil the agreement and to complete the project which includes Rs. 10,193.64 (Rupees ten thousand one hundred ninety three and paisa sixty four only) for payment to the auditor.

2. Lastly, I am pleased to inform that the account has been maintained in accordance with the rules/regulation and instructions of the Pakistan Science Foundation and this institution. The account has been found correct.

Dated: 30 August 1997

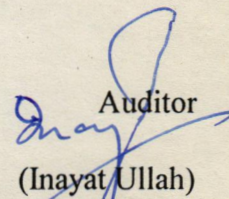
  
Auditor  
(Inayat Ullah)

NEST ACCT  
(COLLEGE OF E&ME)